

TRACK CONDITIONS

Type: Carpet Asphalt Open Med. Tight
 Surface: Indoor Outdoor High Med. Low
 Surface: Smooth Med. Bumpy Track Temp/Air Temp: _____ / _____
 Note: _____

FRONT SUSPENSION

Track Width: _____ mm Gear Diff _____ wt
 Toe Angle: _____ ° Solid Axle (Spool)
 Caster: _____ ° One Way
 Camber: _____ °
 Ride Height: _____ mm Anti-Roll Bar: ∅ _____ mm
 Down Stop: _____ mm

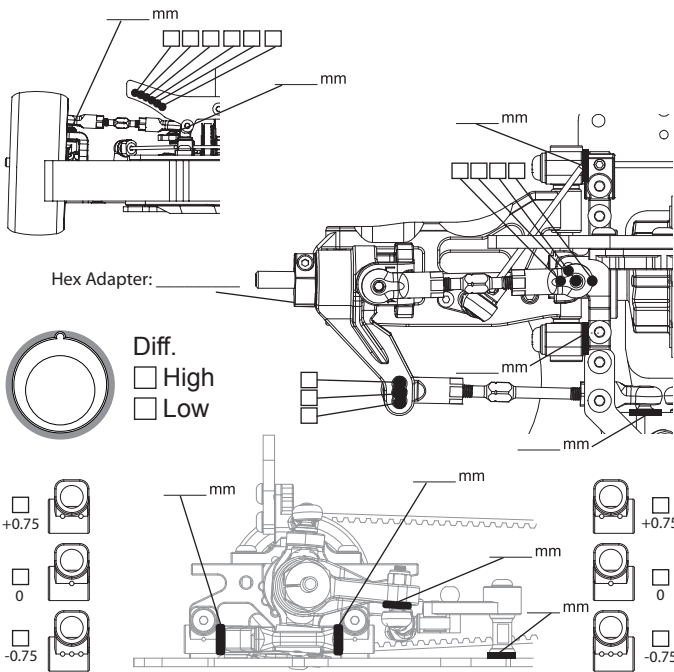

REAR SUSPENSION

Track Width: _____ mm Gear Diff _____ wt
 Toe Angle: _____ °
 Camber: _____ °
 Ride Height: _____ mm
 Down Stop: _____ mm Anti-Roll Bar: ∅ _____ mm

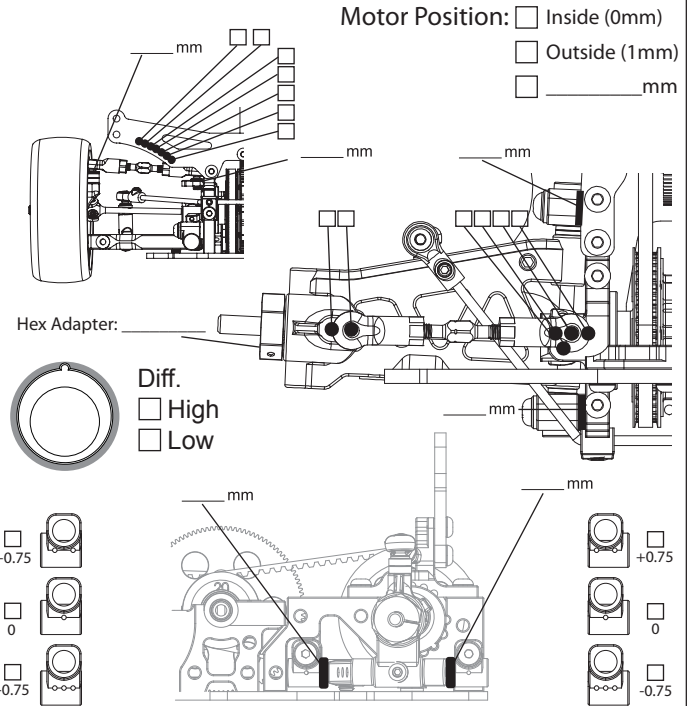

STIFF SETTING

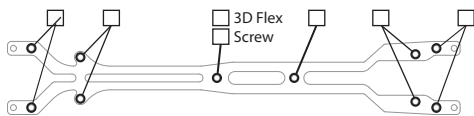

Upper Deck: 2.0mm 2.3mm 2.5mm



Chassis: 2.3mm 2.5mm 3.0mm

ELECTRONICS

Servo: _____
 ESC: _____
 Battery: _____

DRIVE RATIO

$$\frac{\text{Spur}}{\text{Pinion}} \times 1.9 = \text{_____}$$

MOTOR

Brand: _____
 Turns: _____
 Timing: _____

TIRES

Insert: _____
 Wheel: _____
 Shore/deg: _____
 Compound: _____
 Tire Temp: _____
 Tire additive: _____
 Treated Area

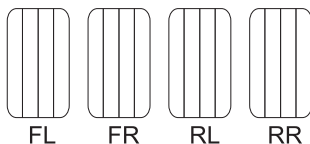

SHOCKS

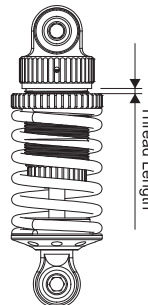

Hole Size: F _____ R _____
 Holes In Piston: F _____ R _____
 Oil wt: F _____ R _____
 Springs: F _____ R _____
 Rebound: F _____ R _____
 Bladder Note: _____
 Thread Length: F _____ R _____

ESC

Punch: _____
 Initial Brake: _____
 Drag Brake: _____
 ESC Timing Turbo Timing

BODY

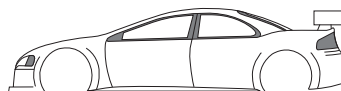

Body: _____
 Wing Height: _____
 Wing Position: _____