

## SETUP SHEET



### TRACK CONDITIONS

Type:  Carpet  Asphalt  Open  Med.  Tight  
 Place:  Indoor  Outdoor Traction:  High  Med.  Low  
 Surface:  Smooth  Med.  Bumpy Track Temp/Air Temp: \_\_\_\_\_ / \_\_\_\_\_  
 Note: \_\_\_\_\_

### FRONT SUSPENSION

Track Width: \_\_\_\_\_ mm  Gear Diff \_\_\_\_\_ wt  
 Toe Angle: \_\_\_\_\_ °  One Way  
 Caster: \_\_\_\_\_ °  Spool  
 Camber: \_\_\_\_\_ °  
 Ride Height: \_\_\_\_\_ mm Anti-Roll Bar: Ø \_\_\_\_\_ mm  
 Down Stop: \_\_\_\_\_ mm

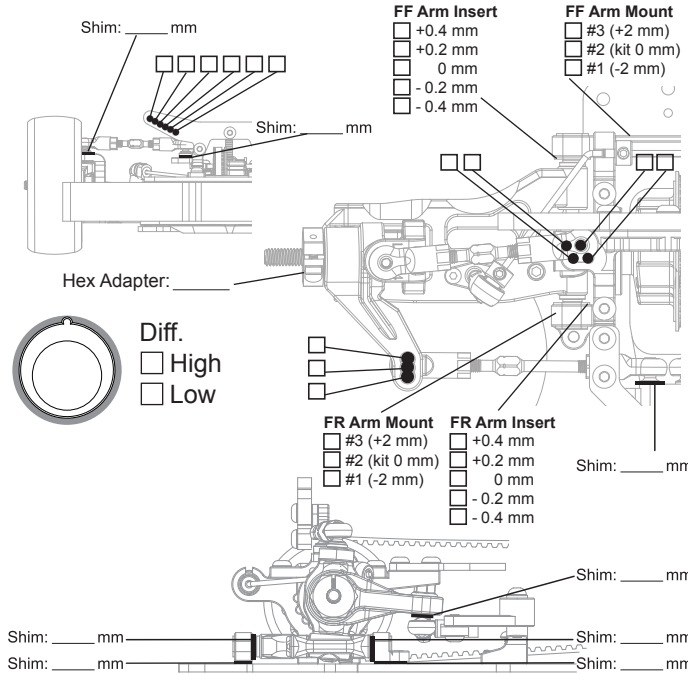

### REAR SUSPENSION

Track Width: \_\_\_\_\_ mm  Gear Diff \_\_\_\_\_ wt  
 Toe Angle: \_\_\_\_\_ °  
 Camber: \_\_\_\_\_ °  
 Ride Height: \_\_\_\_\_ mm  
 Down Stop: \_\_\_\_\_ mm Anti-Roll Bar: Ø \_\_\_\_\_ mm

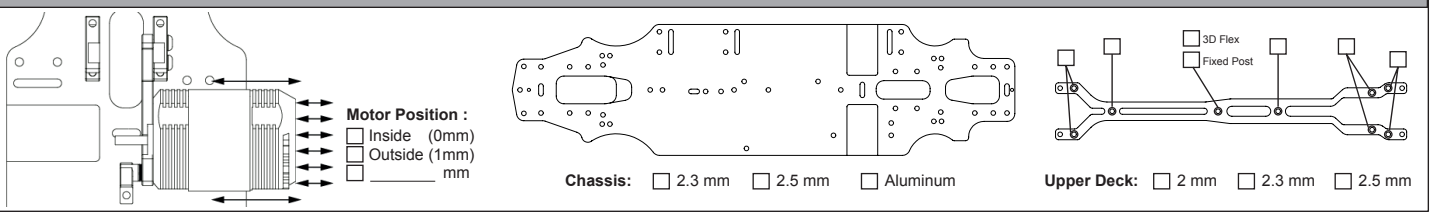
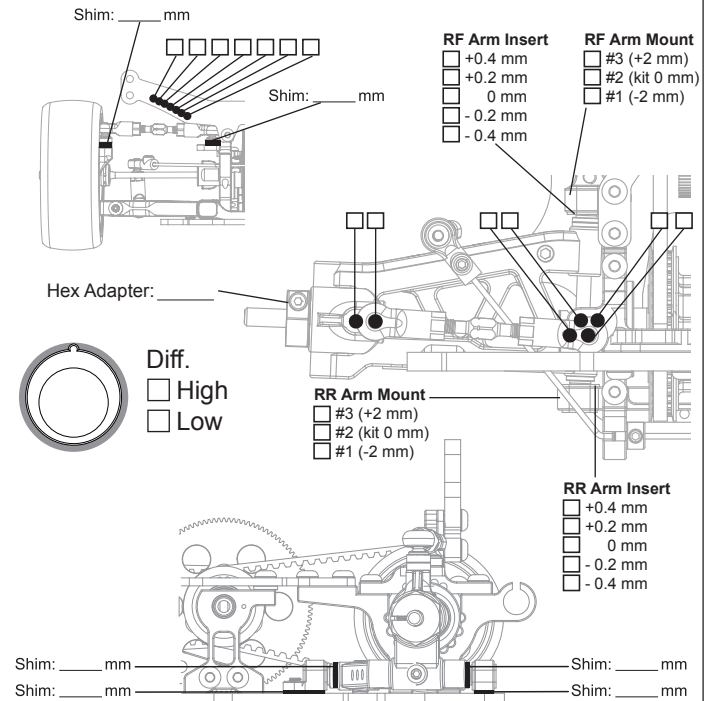

### ELECTRONICS

Servo: \_\_\_\_\_  
 ESC: \_\_\_\_\_  
 Battery: \_\_\_\_\_

### MOTOR

Brand: \_\_\_\_\_  
 Turns: \_\_\_\_\_  
 Timing: \_\_\_\_\_

### ESC

Punch: \_\_\_\_\_  
 Initial Brake: \_\_\_\_\_  
 Drag Brake: \_\_\_\_\_  
 ESC Timing  Turbo Timing

### DRIVE RATIO

Spur  $\frac{T}{T} \times 1.9 =$  \_\_\_\_\_  
 Pinion \_\_\_\_\_

### TIRES

Insert: \_\_\_\_\_  
 Wheel: \_\_\_\_\_  
 Shore/deg: \_\_\_\_\_  
 Compound: \_\_\_\_\_  
 Tire Temp: \_\_\_\_\_  
 Tire additive: \_\_\_\_\_  
 Treated Area

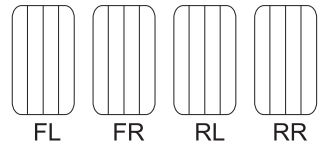

### SHOCKS

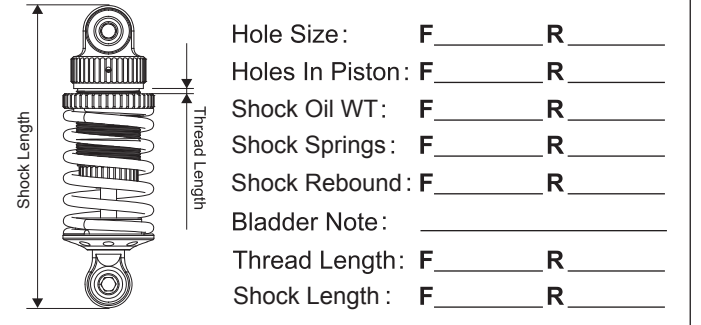

### BODY

